

Spent fuel and radiotoxicity 1/3

Composition of Spent Nuclear Fuel (Standard PWR 33GW/t, 10 yr. cooling)

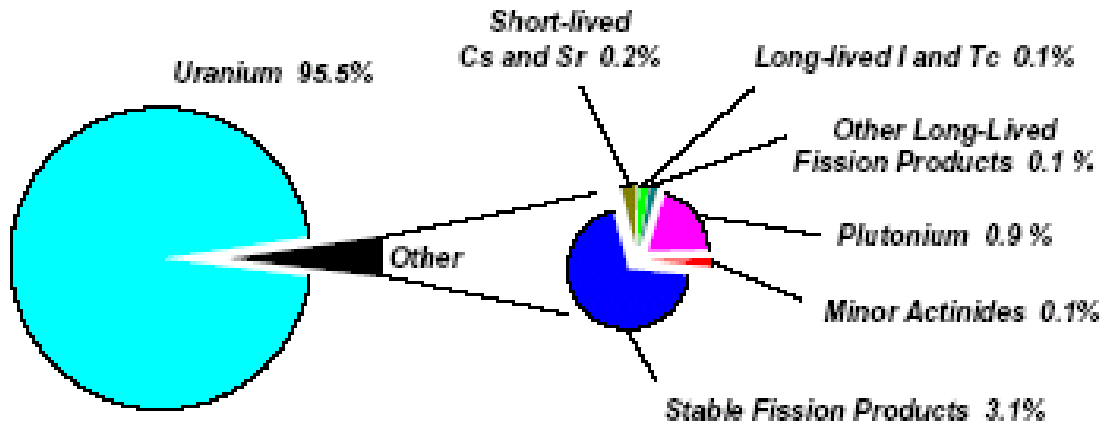

Most of the hazard stems from Pu, MA and some LLFP when released into the environment, and their disposal requires isolation in stable deep geological formations.

A measure of the hazard is provided by the radiotoxicity arising from their radioactive nature.

1 tonne of SNF contains:

955.4 kg U

8,5 kg Pu

Minor Actinides (MAs)

0,5 kg ²³⁷Np

0,6 kg Am

0,02 kg Cm

Long-Lived fission Products (LLFPs)

0,2 kg ¹²⁹I

0,8 kg ⁹⁹Tc

0,7 kg ⁹³Zr

0,3 kg ¹³⁵Cs

Short-Lived fission products (SLFPs)

1 kg ¹³⁷Cs

0,7 kg ⁹⁰Sr

Stable Isotopes

10,1 kg Lanthanides

21,8 kg other stable

Paths of Minor actinide formation in the U-Pu Cycle

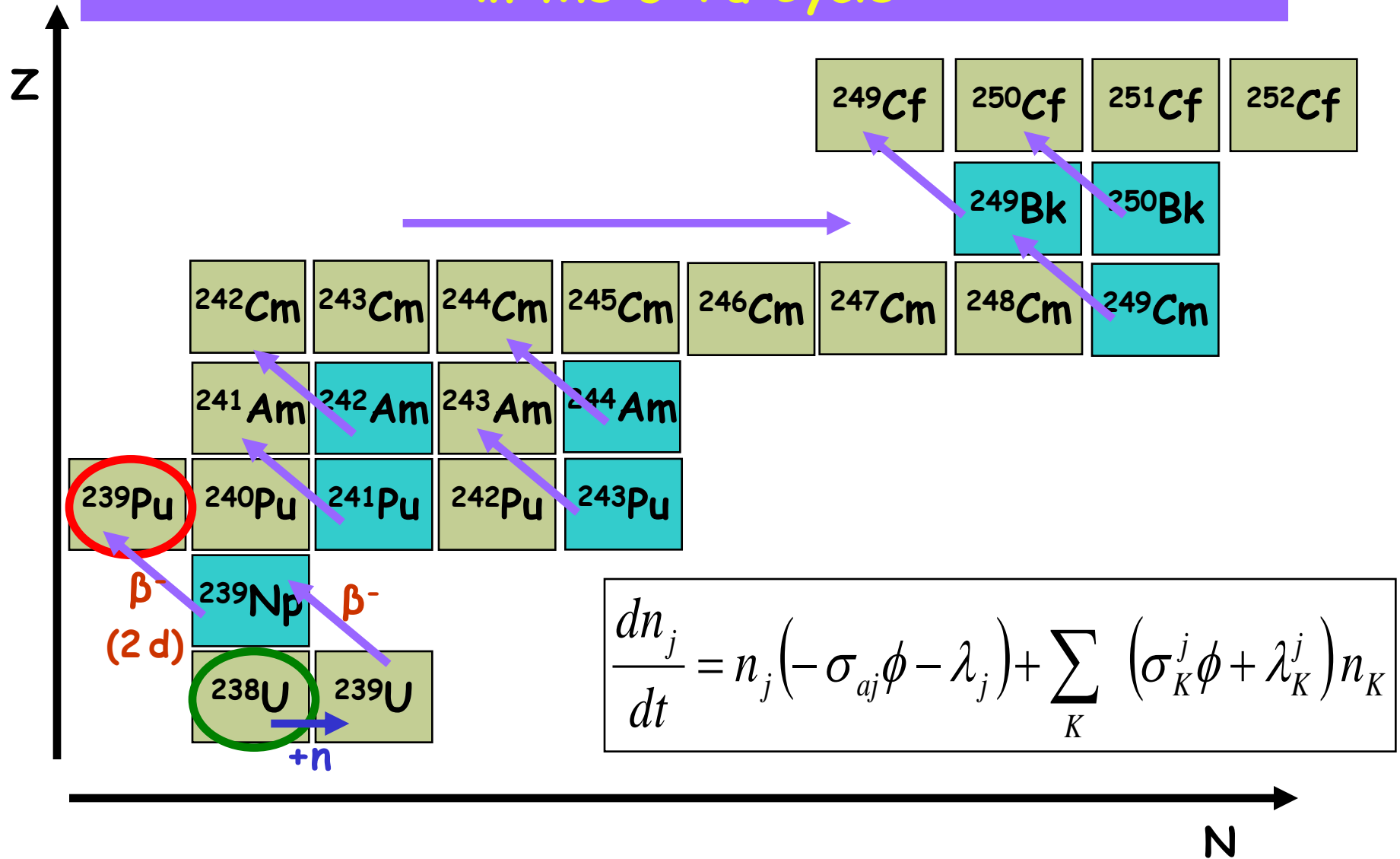

Spent fuel and radiotoxicity 3/3

Evolution of the radiotoxic inventory, expressed in sievert per tonne of initial heavy metal (uranium) (Sv/ihmt) of UOX spent fuel unloaded at 60 GW d/t, versus time (years).

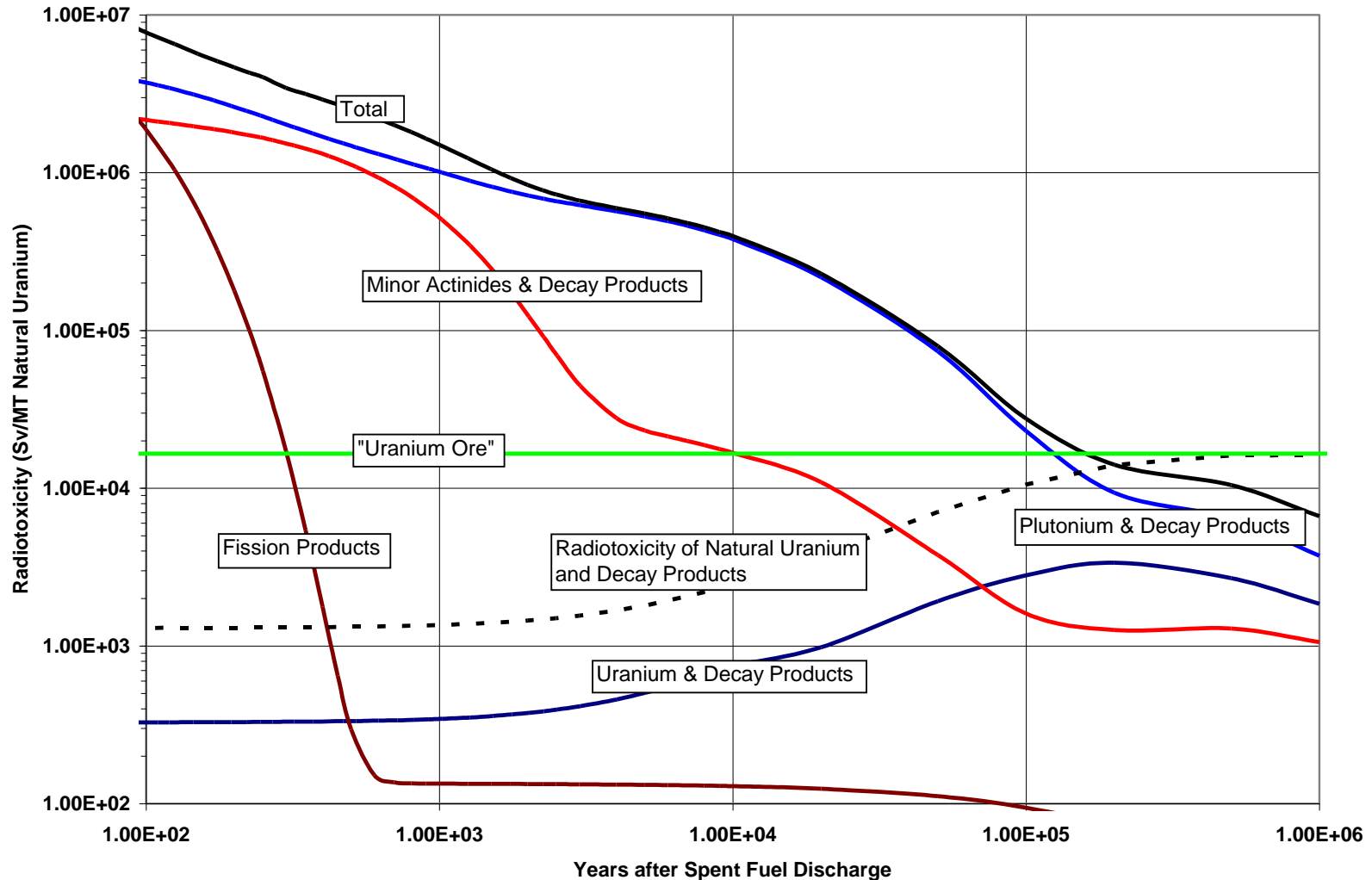

What is Partitioning & Transmutation?

- Use of nuclear reactions to transform long lived nuclides into stable or short-lived nuclides (**transmutation**)
- Chemical separation of these nuclides from HLW is an inevitable ingredient for transmutation (**partitioning**)
- Objectives: Alleviation of the burden of a final disposal and minimization of long-lived nuclides in HLW

P/T applies to **TRU** (**Pu** and **Minor Actinides**) and **Long Lived Fission Products**. It should be kept in mind that **Plutonium** is a special case: it can be considered as a valuable resource or part of the wastes. However, **P/T technologies apply to the most general case.**

A short historical perspective on Partitioning and transmutation (P/T)

From the late seventies to late eighties:

- **Early Partitioning&Transmutatiom studies, mostly in Europe and in the US.**

The physics is first explored together with some pioneering partitioning studies.

- **Early studies on the impact of P/T on fuel cycle, P/T motivations, possible P/T „metrics“ for cost/benefits evaluation.**

- **Both IAEA and EURATOM did issue in the mid-eighties extensive reports with lukewarm conclusions: the challenge did seem to be formidable, without a clear strategy.**

Late eighties- early nineties:

- **The „OMEGA“ initiative in Japan, motivated by a strong public opinion concern about waste management. Japan requests OECD-Nuclear Energy Agency to organize international cooperation and information exchange in the field of P/T**
- **At the same time in France, the waste management issue is discussed at the political level and a law is passed in 1991, in order to study possible strategies (including P/T) during a fifteen years period (1991-2006). A National Commission of Evaluation, appointed by the Government, is put in place.**
- **In the specific US context, the idea of a „Accelerator-driven Transmutation of Wastes (ATW)“ is launched at LANL, based on previous work.**

Since early nineties:

■ **International discussions on „metrics“ and motivations focus on the waste doses or „radiotoxicity“. This notion is controversial: geologists and repository experts say that the potential return to the bio-sphere is dominated by a few LLFP (like I-129), more mobile than TRU (Pigford). Moreover, the contribution to the dose after very long periods of time would be very small.**

■ **However, safety experts point out that, besides scenarios of „normal“ evolution in time of the geological environment, „abnormal“ evolution scenarios, like human intrusion, should be considered. In these scenarios, the „potential source“ of radiotoxicity (e.g. at ingestion), dominated by the TRU is important.**

■ Very significant resources are deployed in particular in Japan, in France (in particular in the field of partitioning, in order to achieve scientific demonstrations of feasibility of different separation processes) and in Europe. The AFCI program is started in the US.

■ A turning point ~2000: the objectives of GENERATION-IV do include P/T (waste minimization). P/T is seen from now on, as consistent with sustainability and non-proliferation objectives: it is the path towards “Advanced Fuel Cycles”.

■ Implementation: closely related to FR deployment decision.

A general scheme for advanced fuel cycles:

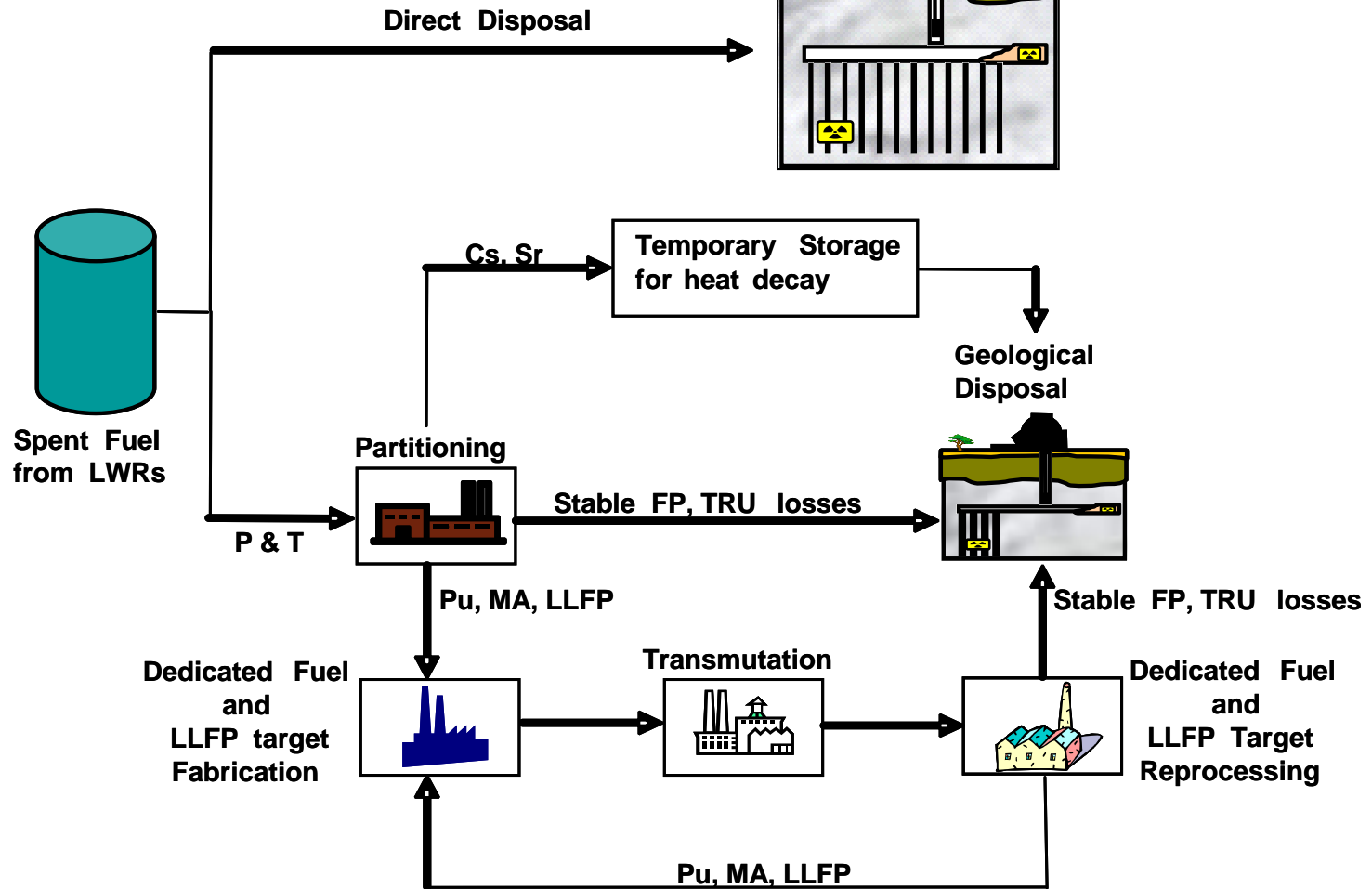

LLFP: Long lived fission products (Tc-99, I-129, Se -79, ...); MA: Minor Actinides (Am, Np, Cm)

Nuclear reactions for transmutation of Long-lived nuclides

- Long-lived nuclides: Minor Actinides & some of LLFP
 - LLFP: FPs with half-life longer than 30 years such as ^{99}Tc (half-life 2×10^5 y), ^{129}I (half-life 1.6×10^7 y)
- Neutron reactions are the only reactions for effective transmutation of MA (neutron fission) and LLFP (neutron capture). However: for MA, neutron fission is always in competition with capture.
- Fast neutrons are best for MA transmutation:
 - Most MA have “threshold” fission (i.e. fission only at high neutron energy)
 - Thermal neutrons produce, via neutron capture, more high atomic number MA than cause fission of MA
 - More favourable fission-to-capture probability ratio with fast neutrons
- Thermal neutrons better for LLFP transmutation (higher capture probabilities) but transmutation rate is very slow. No major benefits, even if LLFP more “mobile” in geological environment.
- No effective means of transmutation of Sr-90, Cs-137 (half-lives ~30 yrs)

Main features of fast neutron reactor physics:



Favorable neutron economy with respect to thermal neutron spectrum reactors:

Fission-to-Absorption Ratio for PWR and SFR

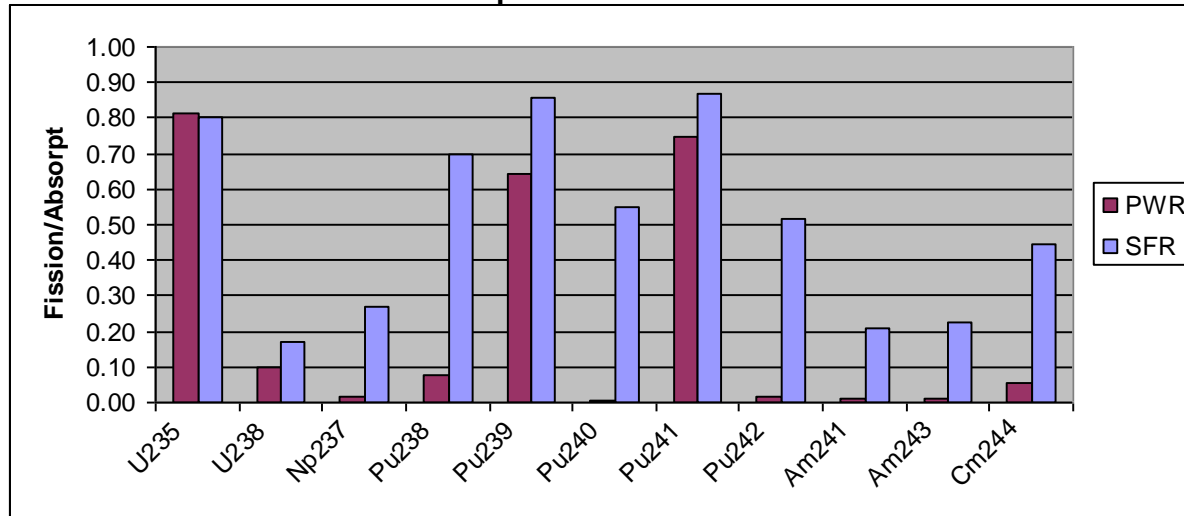

Fissile isotopes are likely to fission in both thermal/fast spectrum

However, the fission fraction is higher in fast spectrum

Moreover, significant (up to 50%) fission of fertile isotopes in a fast spectrum

Net result is more excess neutrons and less higher actinide generation in FR

Three major scenarios to implement P/T:

- a) **Sustainable** development of nuclear energy with **waste minimisation**.
One type of reactor, one fuel type, one reprocessing process
 - b) **„Double strata“** fuel cycle: 1) commercial reactors with Pu utilisation 2) separate MA management. Two separate fuel cycles.
- ➔ The two previous scenarios imply the **continuous use of nuclear energy**, the **stabilisation of the TRU** stocks in the fuel cycle and the **minimisation of wastes** in a repository.
- c) **Reduction of TRU stockpiles** (e.g. as a legacy from the past operation of power plants)
- ➔ **All three scenarios** go beyond the strategy of „once-through“ („open“) fuel cycle (i.e. the final storage of irradiated fuel), and **imply fuel reprocessing**.

a) Reference scenario for a sustainable development of nuclear energy with waste minimisation

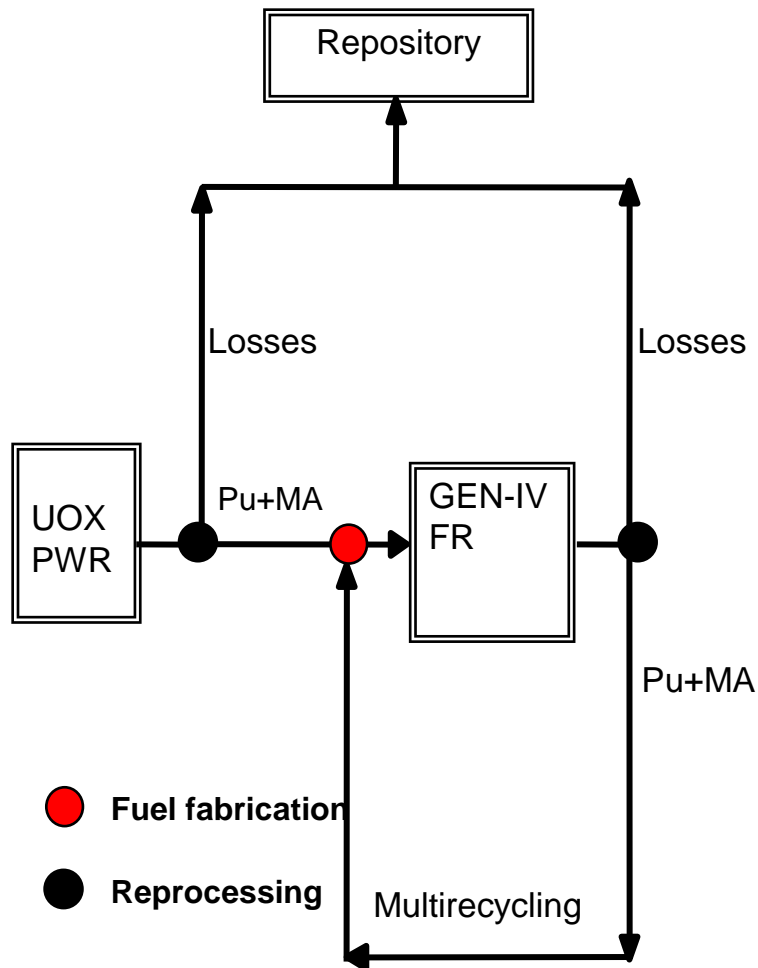

CR = Conversion ratio = fissile material produced/fissile material destroyed.
CR < 1 -> „burner“; CR > 1 -> „breeder“

- ➡ The multiple recycle of TRU is feasible in a Fast Reactor (FR), whatever its coolant and fuel type: oxide, metal, carbide or nitride
- ➡ 2-5% MA in the fuel: close to standard fuel, if **homogeneous** recycle chosen and CR > 0.8
- ➡ **Some impact on the fuel cycle**, e.g. at fuel fabrication, due to the Cm-244 spontaneous fission neutron emission
- ➡ Reprocessing needed to recover not-separated TRU (enhanced proliferation resistance)
- ➡ A possible variant: **heterogeneous** (i.e. target) recycle of MA at the periphery of the core, while Pu recycled as standard fuel in the core. Needs separation of MA from Pu.
Impact on fuel cycle being evaluated.

Scenario a) : Why not **Thermal** instead of **Fast** Reactors?

Consequences on fuel cycle parameters of full TRU recycling in LWRs, e.g. at fuel fabrication:

Parameter	Multiplying factor ^(a)
Activity	~0.5
α -heat	~ 3
β -heat	~ 0.5
γ -heat	~ 3.5
neutron source	~ 8000

- Unacceptably high – Effect due to high capture cross-sections in thermal spectra, which favour.. Cf-252 production !

^(a)Reference value (=1): case of Pu-only multirecycling

Cf-252 inventory in the core. Case of full TRU multirecycling in a LWR

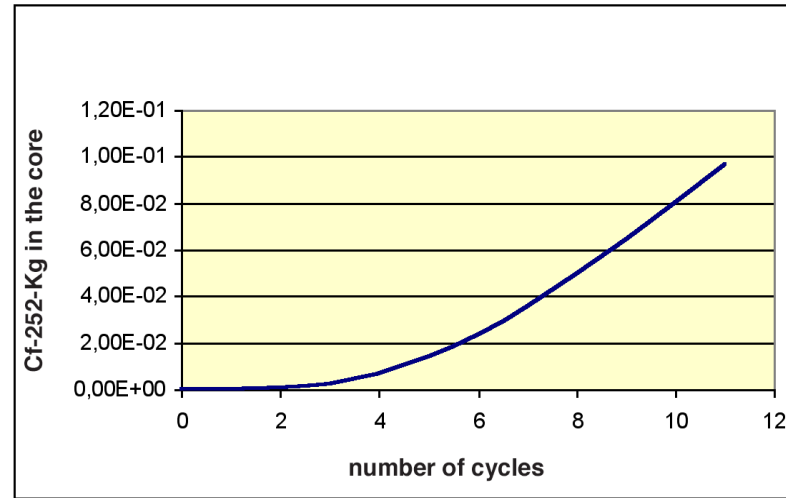

Cf-252 inventory in the core. Case of full TRU multirecycling in a FR

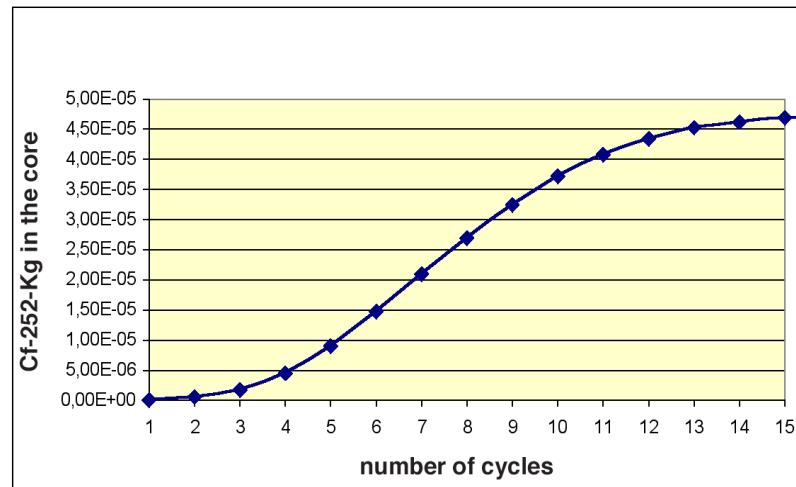

b) « Double strata »: Pu still a resource. Gen-IV FR deployment delayed

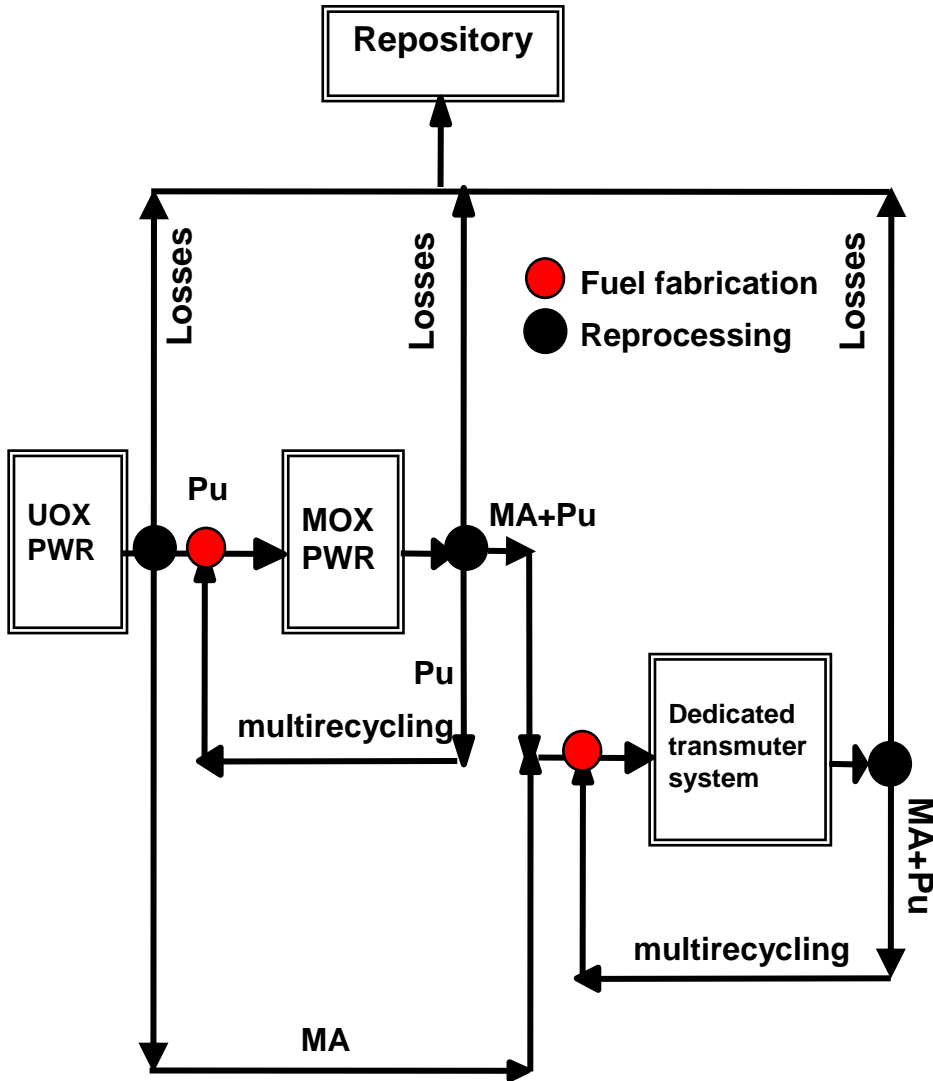

- The Pu inventory can be stabilized.
- MA management in dedicated transmuter systems: e.g. subcritical Accelerator Driven Systems (**ADS**) with U-free (?) fuels or critical FR with low CR. Also: Fusion/Fission Hybrids
- Fuel: New fuel (with high MA content) needs to be developed.
- Reprocessing: to be developed in particular for U-free fuels. **Choice of support matrix in fuel is relevant.**
- Potential impact on the fuel cycle (**high decay heat, high neutron emissions**)
- The „**support**“ ratio, i.e. the ratio of total power of the dedicated systems to the total power of the power generating systems is of the order of 6%

c) Reduction of Pu+MA stockpile (Pu considered as waste)

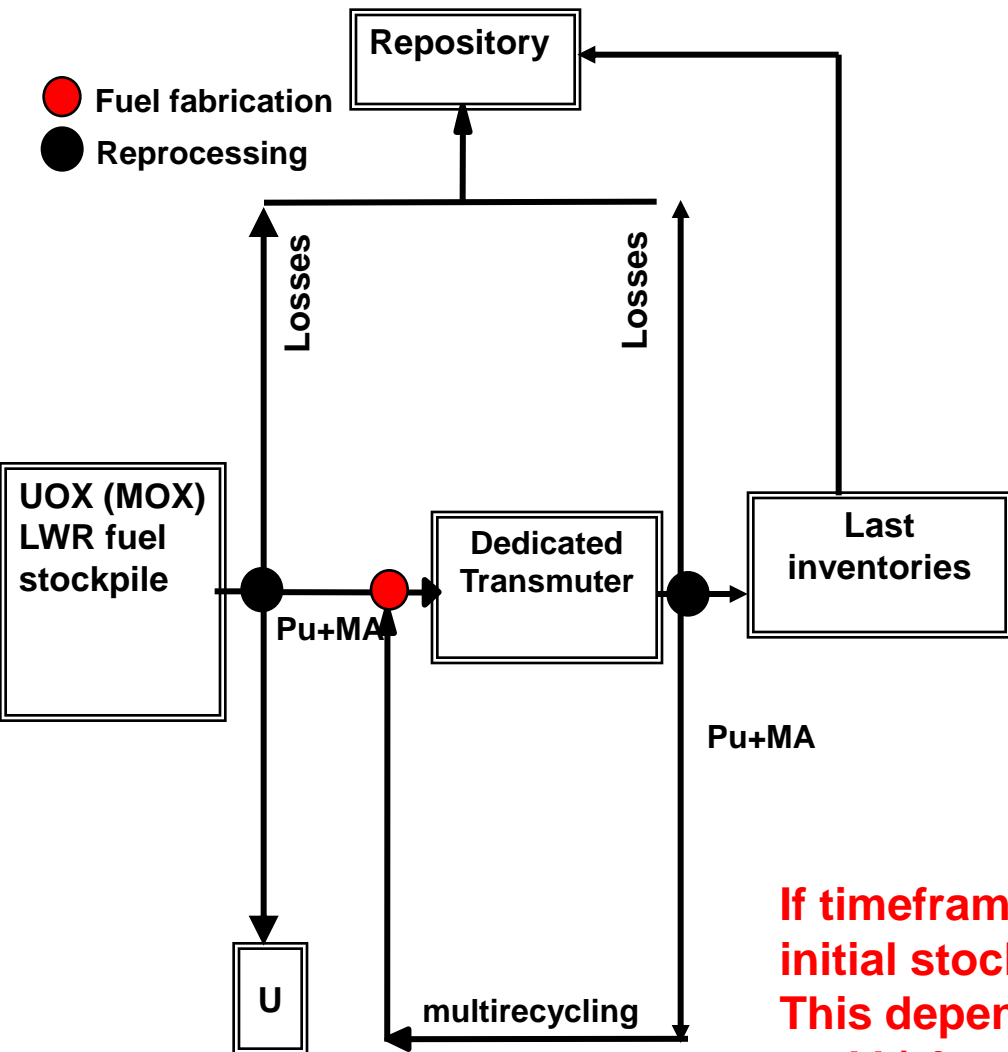

→ **Limited number of dedicated transmuters:** need to account for last transmuter in-core inventories

→ **Fuel (U-free?) in the dedicated transmuters:** Pu/MA $\sim 10/(1-1.5)$ to be developed

→ **New Fabrication processes needed.**

→ **Reprocessing of transmuter fuel:** to be developed.

→ **Potential impact on the fuel cycle**

If timeframe for reducing stockpile ~ 100 y, $\sim 20\%$ of initial stockpile is not burnt.

This depends on a) transmutation rate ($\sim 5\%/year$) and b) from fuel cycle characteristics (e.g. cooling time, reprocessing and re-fabrication time)

Potential benefits of P/T

In principle, P/T offers significant potential benefits to the fuel cycle:

- Reduction of the potential source of radiotoxicity in a deep geological storage („intrusion“ scenario)
- Reduction of the heat load: larger amount of wastes can be stored in the same repository
- If TRU are not separated (e.g. in the homogeneous recycling in a Fast Neutron Reactor), improved proliferation resistance is expected
- **However, still a debated issue between P&T and Waste Management Communities (which are the “good” metrics?)**
- **Results obtained in different studies in the USA, in Japan and in Europe**
- **A comparative analysis is underway within the OECD-NEA**

Impact of the actinides management strategy on the radiotoxicity / Activity of ultimate Waste (wide international consensus)

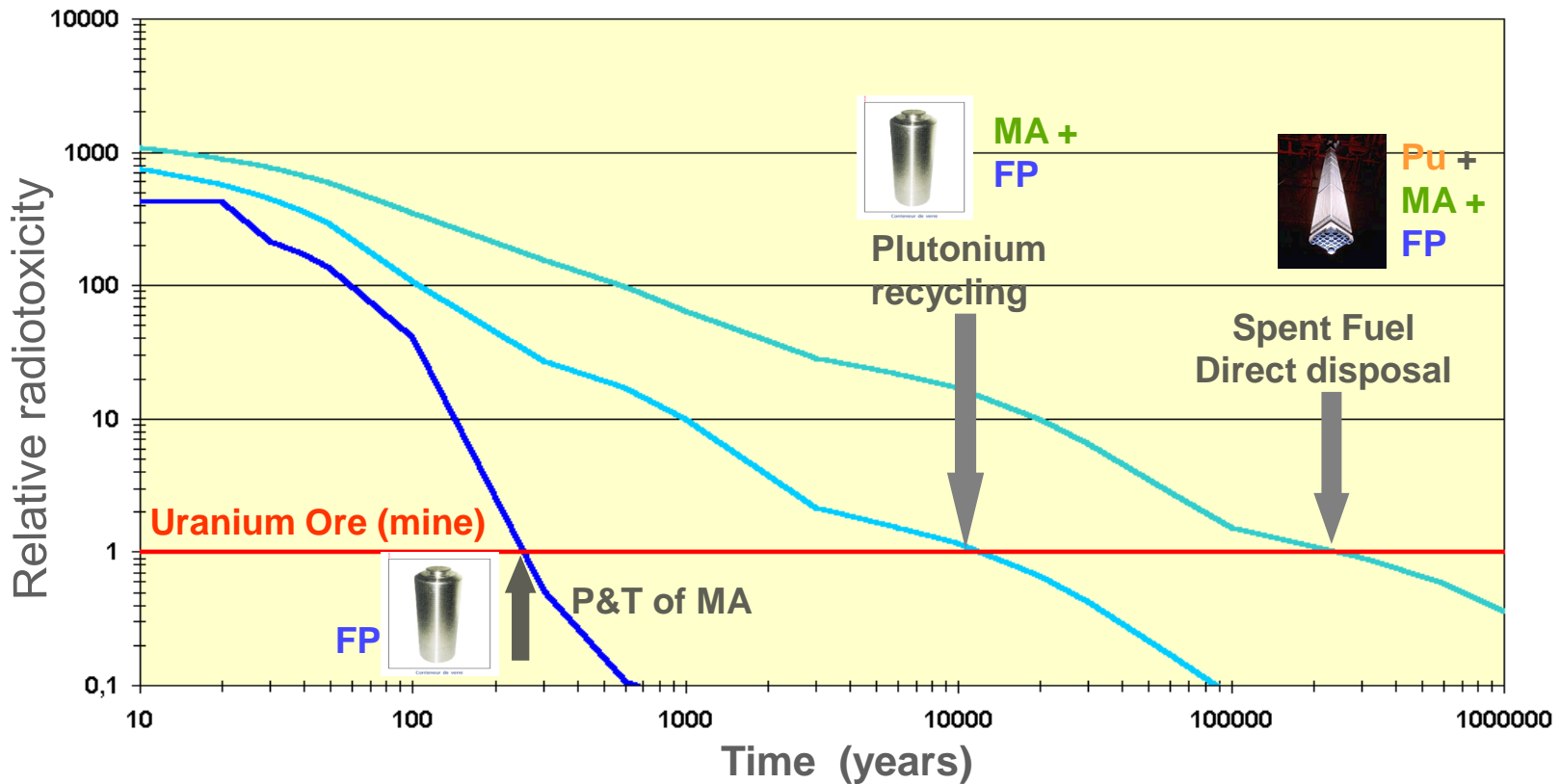

Recycle of all actinides in spent LWR fuel in fast reactors provides a significant **reduction in the time required for radiotoxicity to decrease to that of the original natural uranium ore** used for the LWR fuel (i.e., man-made impact is eliminated)

From **250,000** years down to about **400** years with **0.1%** actinide loss to wastes

Decay Heat and Yucca Mountain Repository Loading

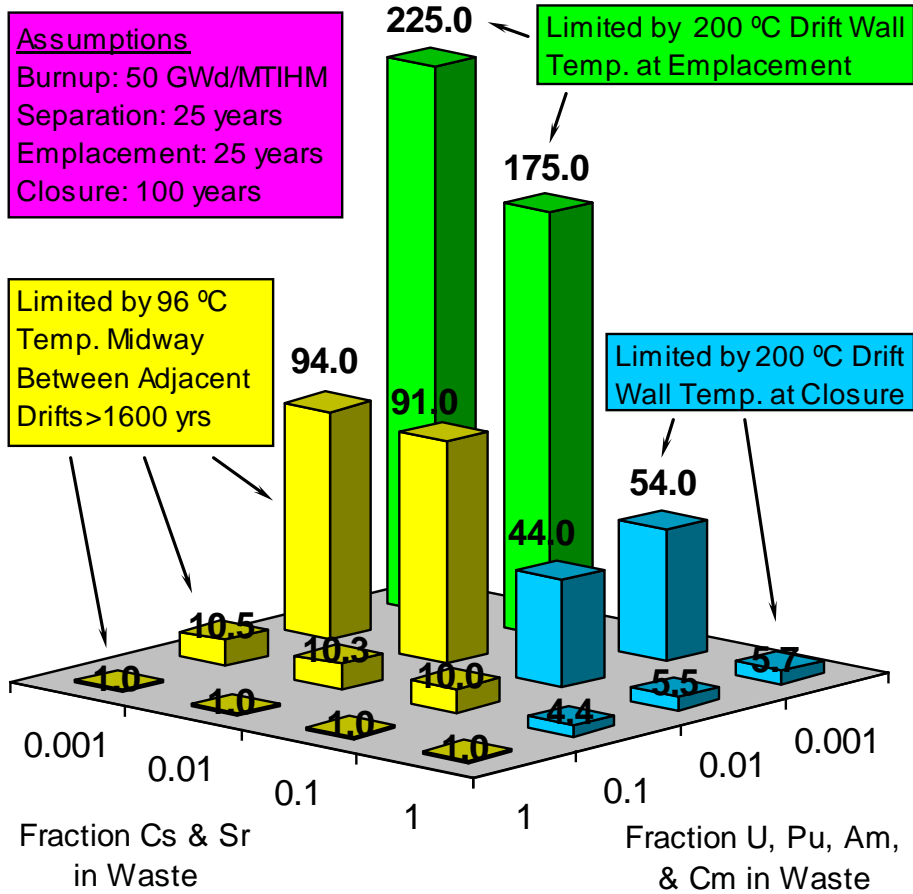

- **The figure shows the potential increase in drift loading as a function of the inventory of actinides and fission products in the waste stream**
 - Removal of Pu/Am/Cm (decay heat) and U (volume) would permit the waste from about 5.7 times as much spent fuel to be placed in the space that spent fuel would require
 - Removal of Cs & Sr only would have no impact
 - Removal of the U/Pu/Am/Cm and Cs & Sr would permit the waste from up to about 225 times as much spent fuel to be placed in the space that the spent fuel would require
- Suitable waste forms would need to be available to fully realize such benefits
- Other repository environments could respond differently

Potential increase in drift loading on an energy-generated basis

Discussion in Check and Review on P&T in Japan, 2008

Three points are addressed in the draft report:

(1) Reduction of Potential Hazard

- The geological disposal of HLW is regarded as an extremely effective way to decrease the risk sufficiently.
- P&T possibly reduces the long-lasting potential hazard of HLW.
- Decontamination factor of actinides is an important factor.

(2) Mitigation of Requirements for Geological Disposal Site

- In the case of MOX-LWR and FR, MA transmutation reduces the site area for disposal of HLW because of Am-241 accumulation.
- It will also result in the reduction of the time period for storage before disposal.
- There are, therefore, possibilities to prolong the time period necessary to find the next site.

(3) Increase of Degree of Freedom in the Design of the Waste Disposal System

- P&T of MA and the partitioning of heat-generating FP coupled with long-term storage of the waste forms may reduce the site area for the geological disposal.
- This increases the “degree of freedom” to rationalize the design of the “waste disposal system”.
- More detailed study is, however, necessary for concrete methods of long-term storage of Sr-Cs and their disposal.

Estimation of Repository Area: Coupling with Long-term Storage of Sr-Cs

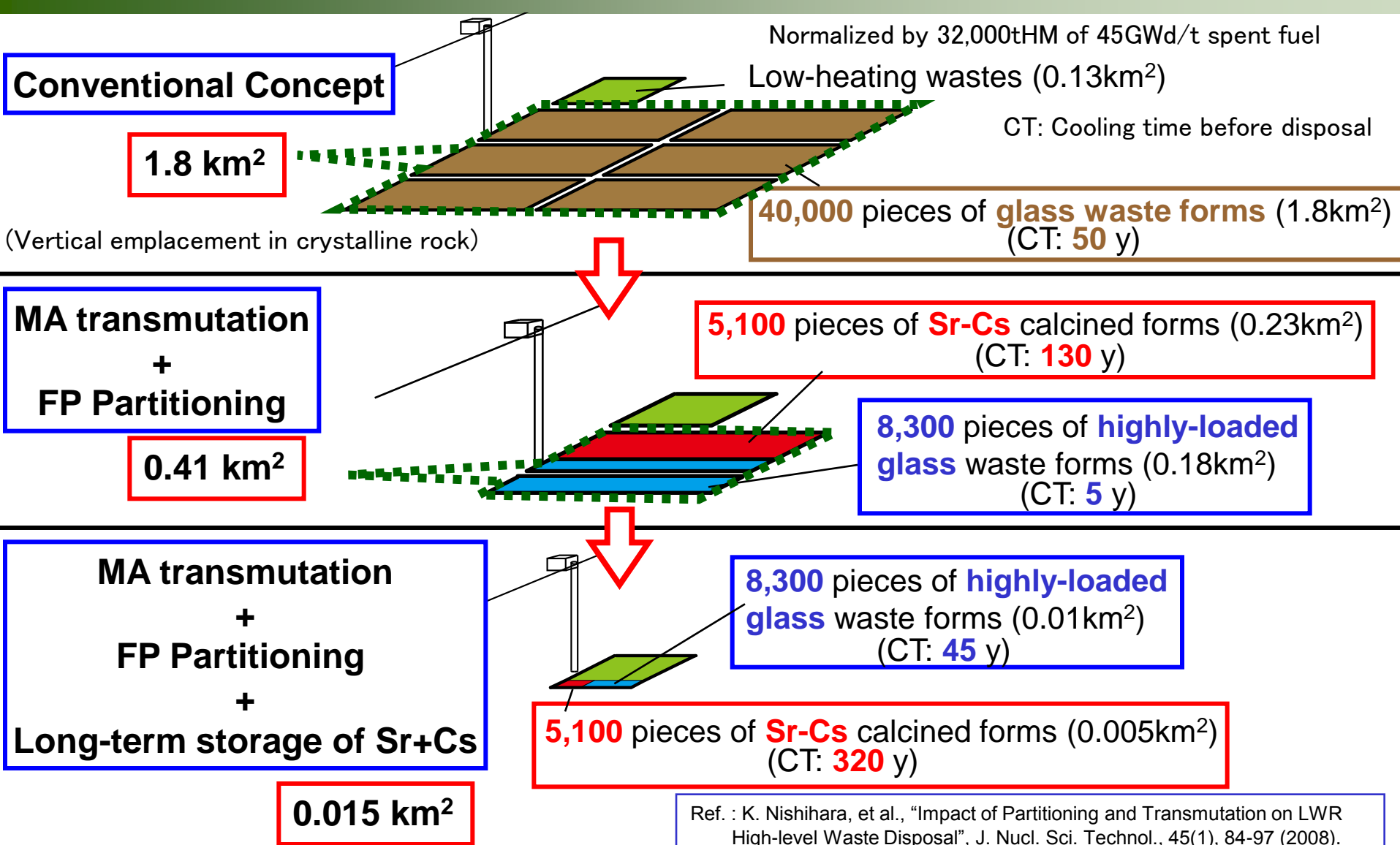

Challenges for the development and implementation of advanced fuel cycles with P&T

- The **Physics of Transmutation** is well understood: experiments have been performed irradiating pure TRU isotope samples in power reactors, and transmutation rates have been compared successfully to calculations.
- **Chemistry of isotope partitioning** and **MA-based fuels** development are major challenges. Moreover, an **industrial deployment** implies to upgrade the most promising technologies from the laboratory scale. **Cm management** and, in general, the **impact on fuel cycle** (decay heat, neutron sources) are challenging issues.
- The **optimisation** (economy, safety, transmutation performance) of **innovative critical fast reactors**, and the **ADS feasibility** are also significant challenges.
- The implementation of advanced fuel cycles could require a **new regional approach**, in order to share facilities and to optimize resources
- **Overall cost** considerations are of course essential.

A few examples:

Technical challenges to Actinide Separations

- ✓ **Chemistry of actinides is complex: actinides form multiple valence states, similar to that of lanthanides**
- ✓ **„Grouped“ separation of TRU**
- ✓ **Process losses reduction**
- ✓ **Production and management of the secondary wastes**
- ✓ **Cost reductions**

Aqueous and Dry (pyrochemical) processes can be used and are developed

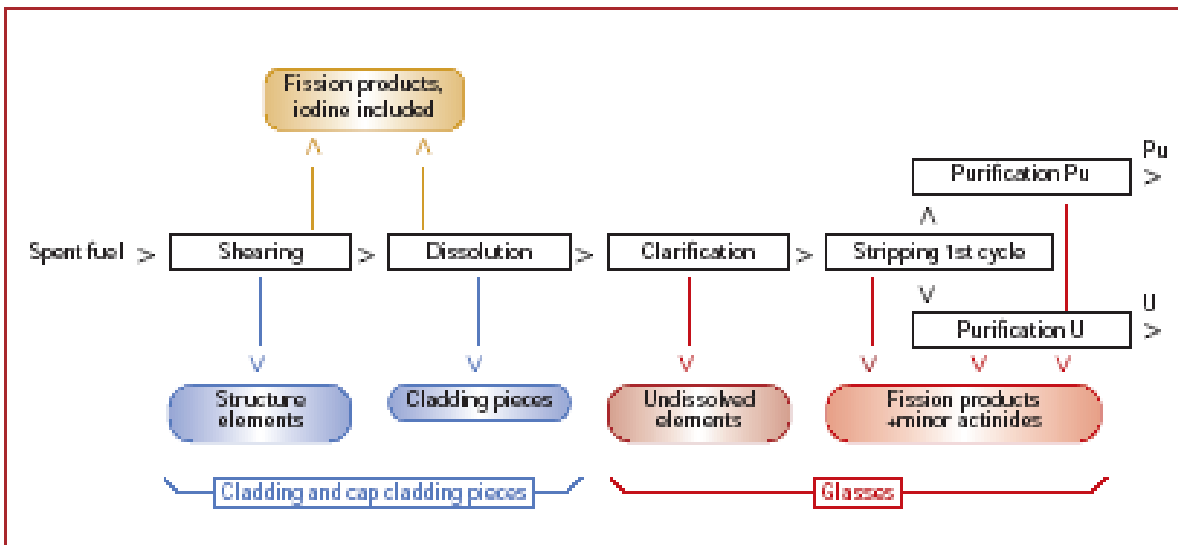

Figure C.1: basic diagram of the Purex process.

In France, significant developments to go from the PUREX process of today...

...to enhanced partitioning scheme and their demonstration:

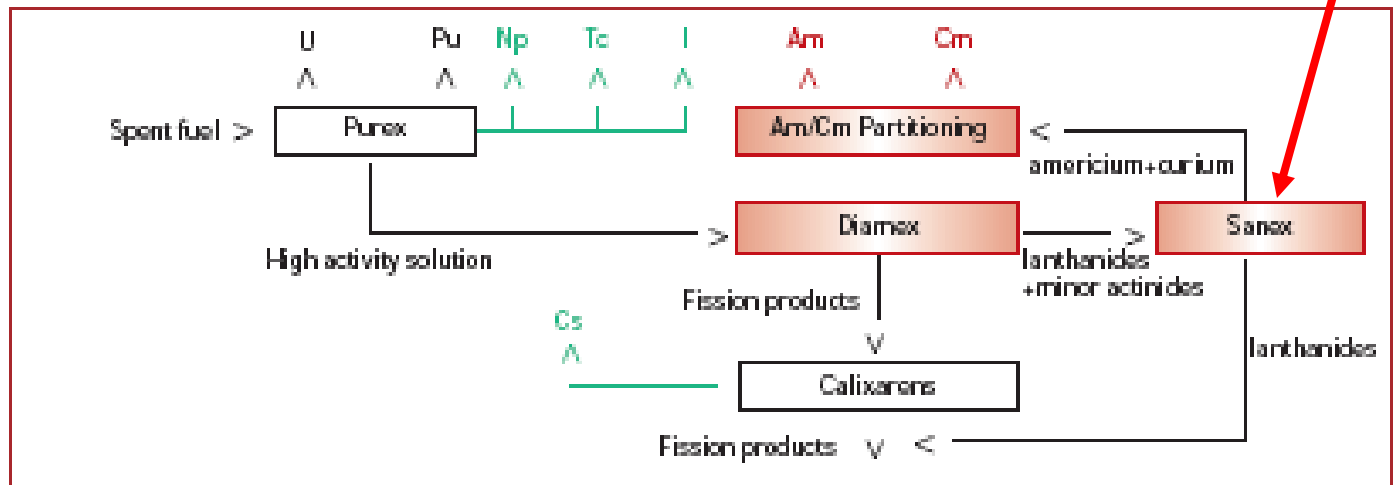
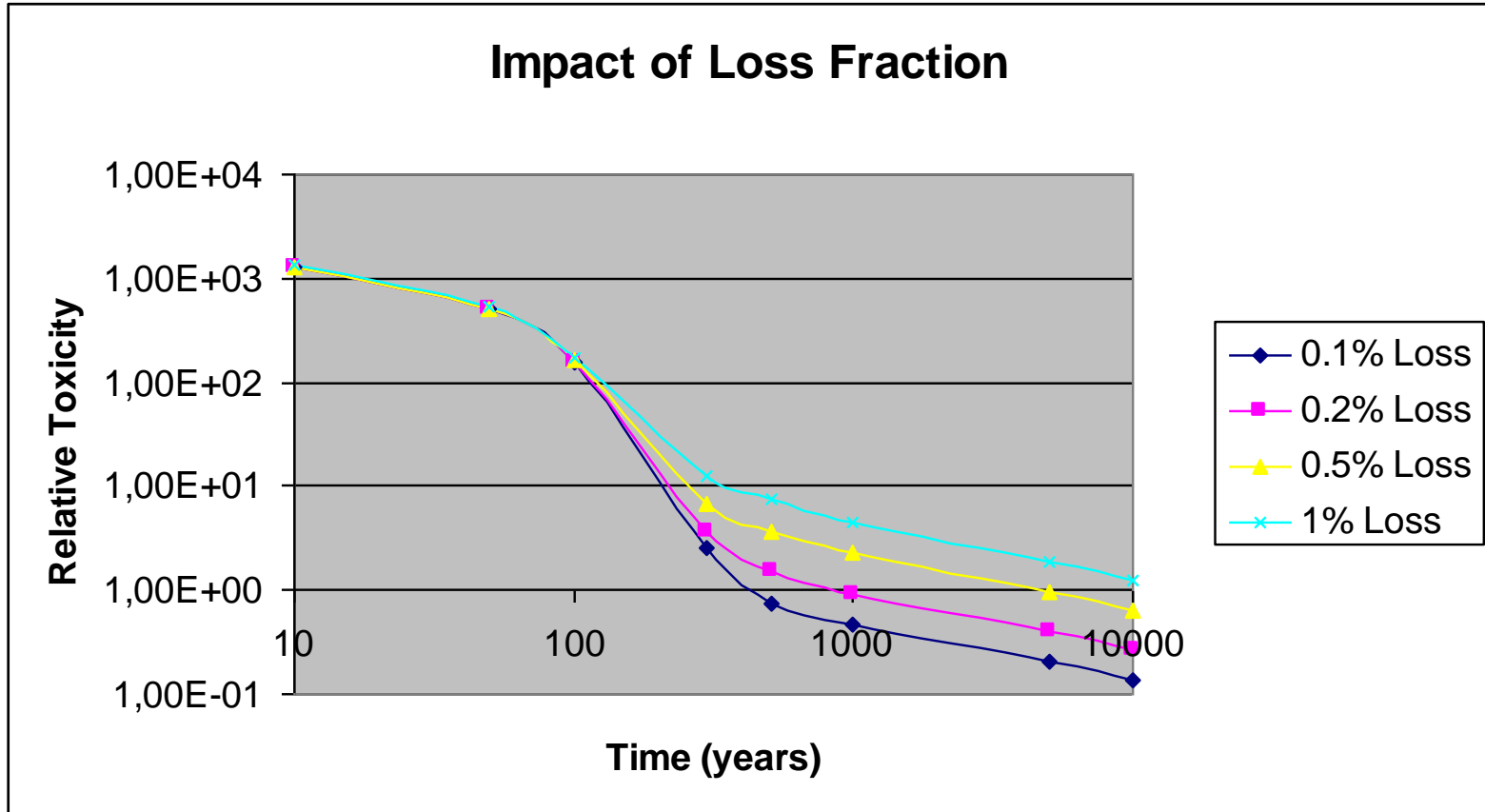

Figure C.2: enhanced partitioning scheme.

Importance of Processing Loss Fraction



Radiotoxicity goal cannot be achieved if loss fraction increases beyond 0.2%, and extends to 10,000 years at 1% losses

An example: Result of Sanex process, Atalante hot run, 2005

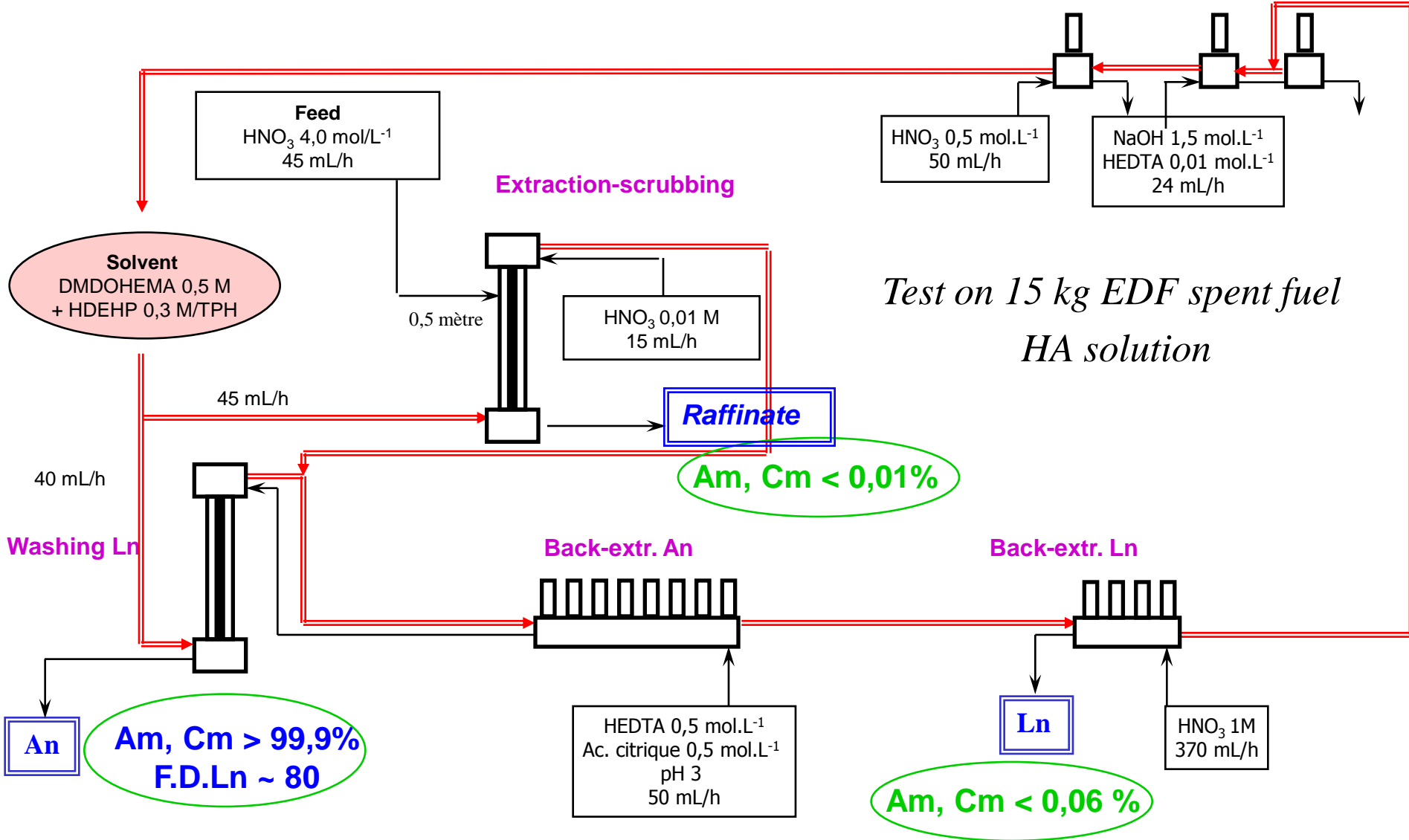

Technical challenges to Fuel Development

- ✓ Large decay heat and high neutron emission of MA give new problems with respect to standard fuel manufacturing
- ✓ However problems are smaller if the fuel contains U and small amount of MA (as in the case of scenario a) with respect to U-free fuels (as in the case of scenario b) and c)) with large amounts of MA.
- ✓ In the case of U-free fuels, the choice of the support/matrix (e.g. for oxide fuels: MgO, ZrO₂, Mo...) is crucial for a good thermal behaviour under irradiation.
- ✓ Fabrication processes are challenging (avoid contamination etc.), in particular for a significant content of Cm.
- ✓ In any case, remote handling is needed

Transmutation fuel development is considerably more challenging than conventional fuels

- **Multiple elements in the fuel**
U, Pu, Np, Am, Cm
- **Varying thermodynamic properties**
e.g. High vapor pressure of Am
- **Impurities from separation process**
e.g. High lanthanide carryover
- **High burnup requirements**
- **High helium production during irradiation**
- **Remote fabrication & quality control**
- **Fuel must be qualified for a variable range of composition**
 - Age and burnup of LWR SNF
 - Changes through multiple passes in FR
 - Variable conversion ratio for FR

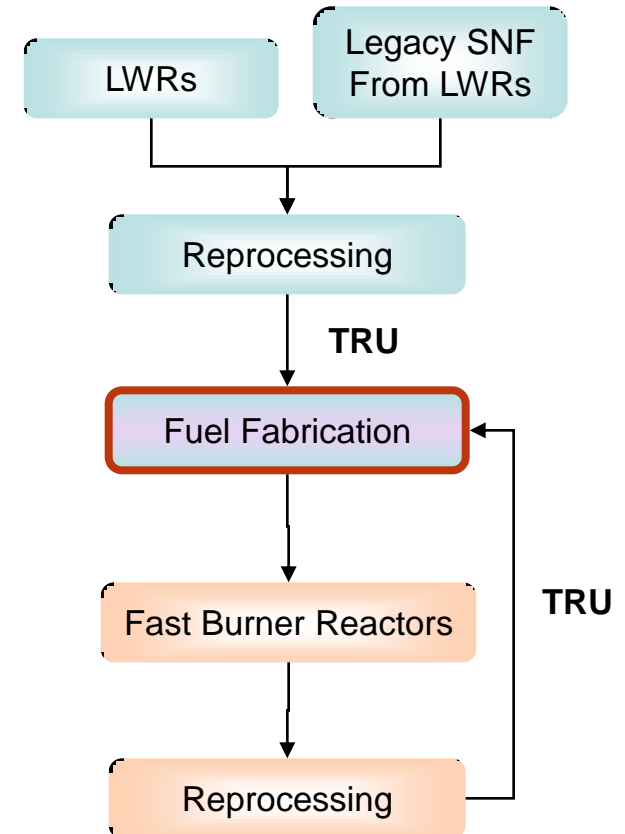

In the fuel area, experimental results and challenges for both homogeneous and heterogeneous recycle:

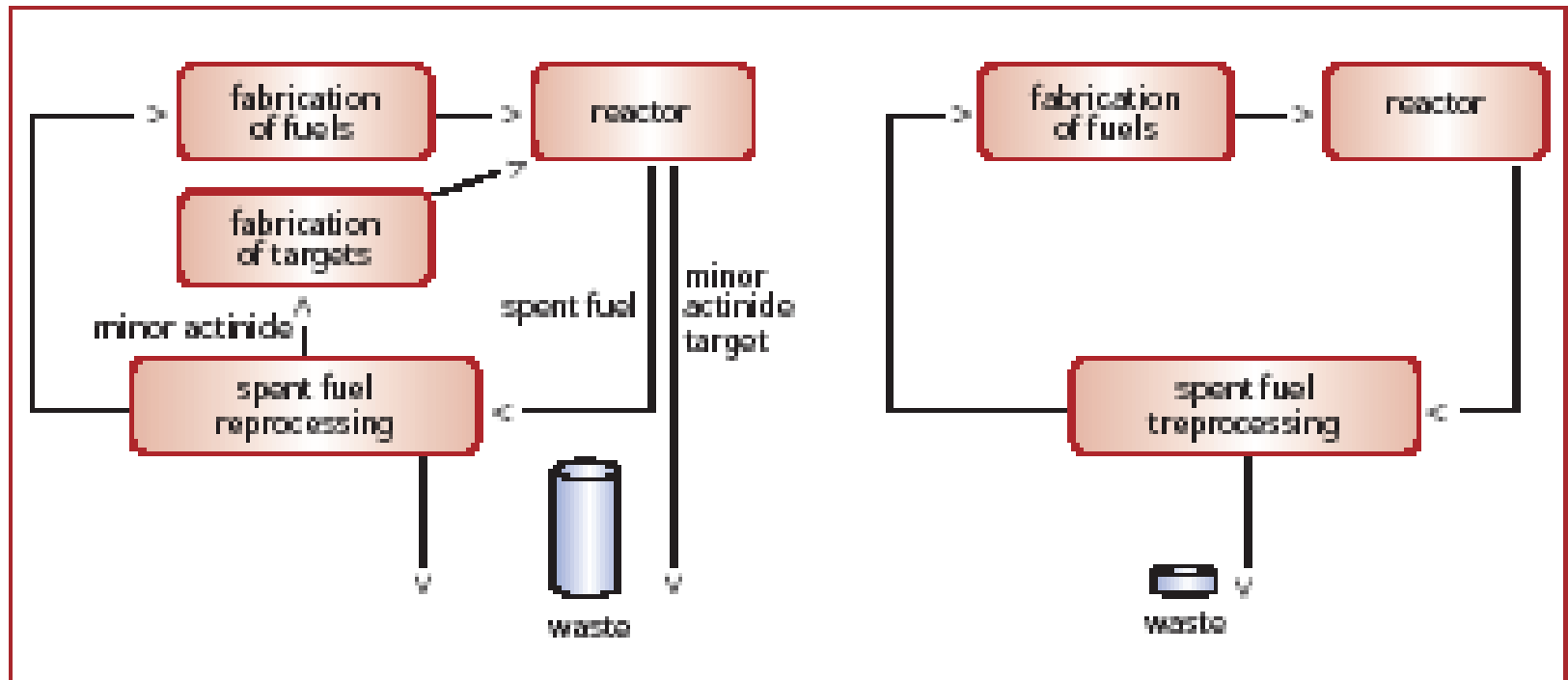

Figure D.4: Principle of minor actinide transmutation in mono-recycling with targets (left) and in multi-recycling with fuels (right).

Demonstration of homogeneous recycle in metal fuel...

Figure 14. Irradiation test pins for METAPHIX (unit : mm) A, C: U-Pu-Zr reference specimen; B: U-Pu-Zr-MA-RE specimen (diameter of pin = 0.55 mm, cladding = 15/15Ti cw)

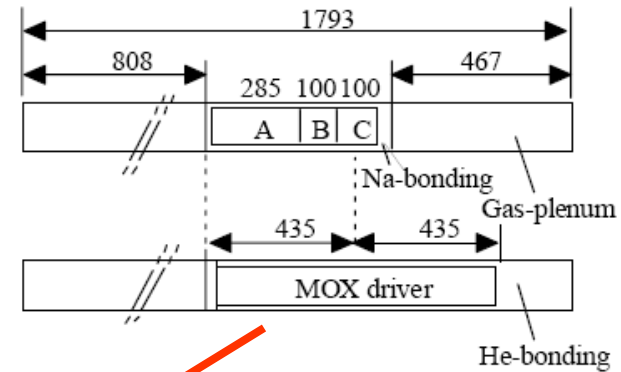
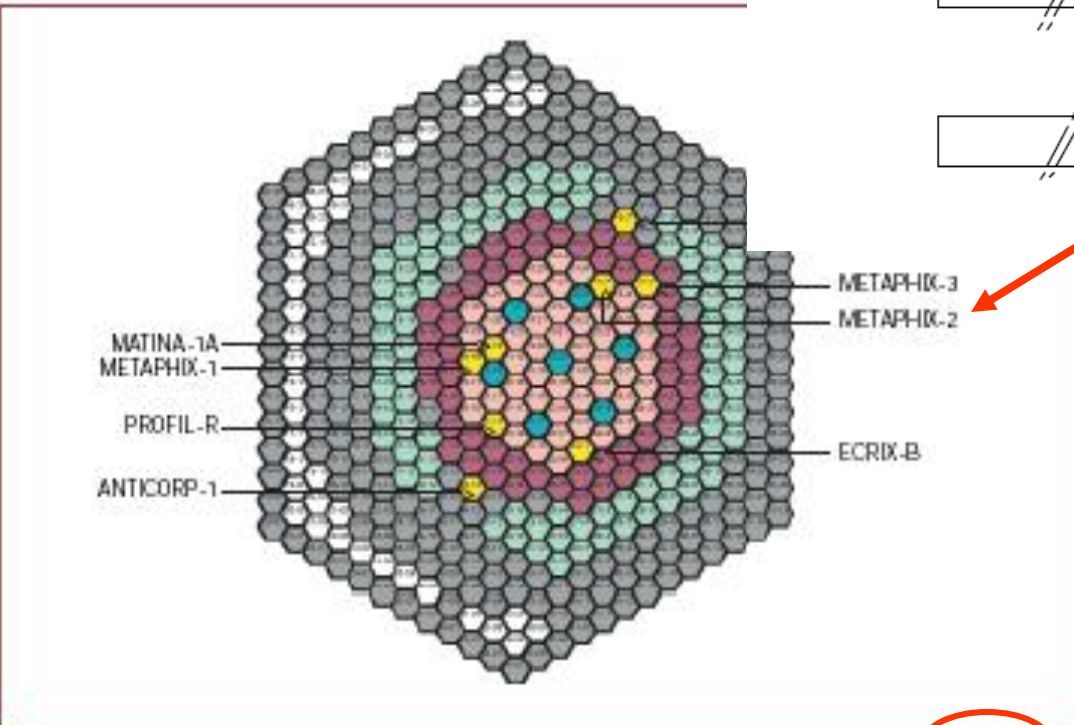

Figure D.11: position of the eight assemblies (in yellow) for transmutation experiments in the Phenix core in early 2004.

...and of target in different environments:

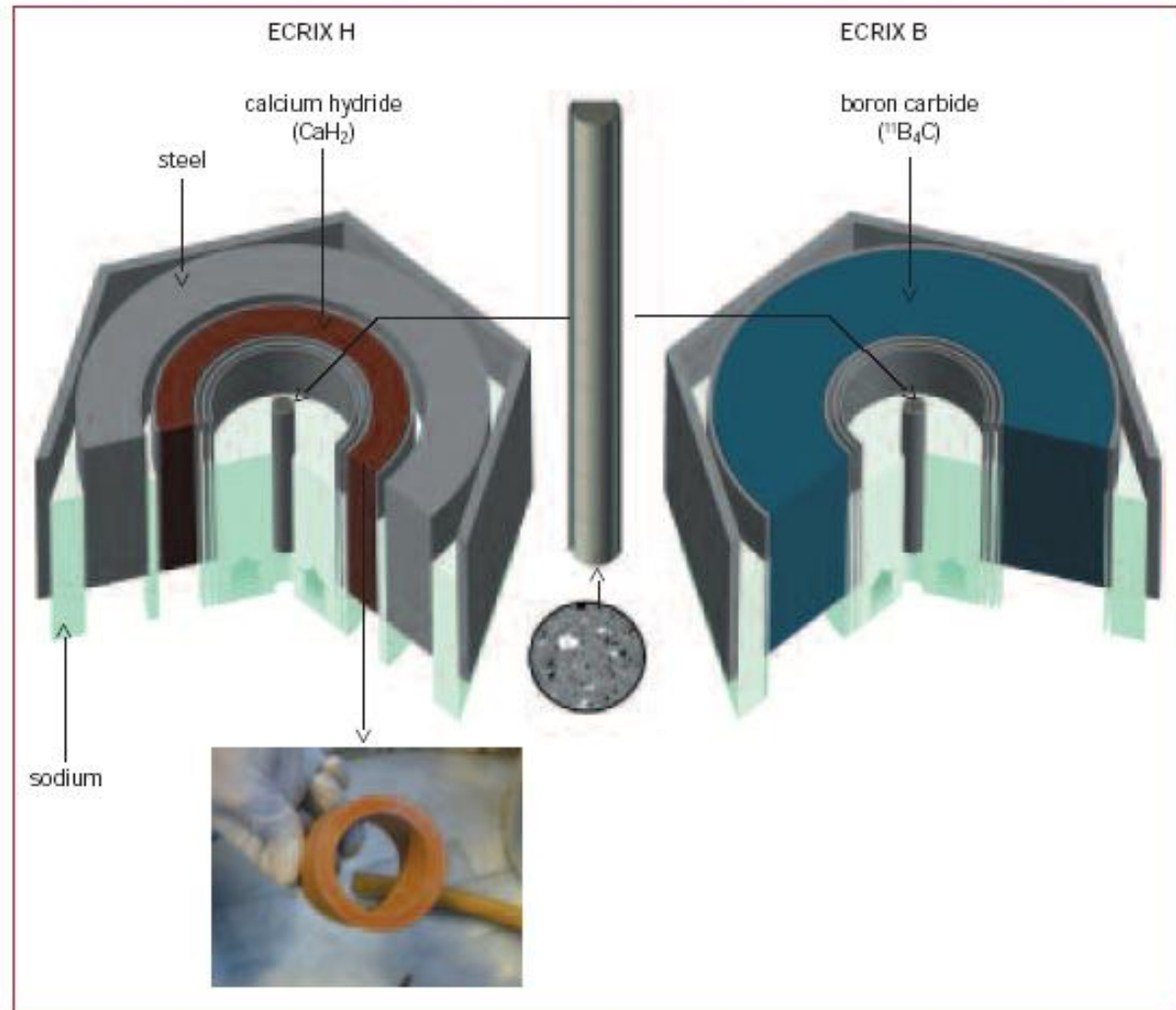

Figure D.14: positions of the moderator and of the target minor actinide pin in an experimental Phenix assembly.

A Generation-IV Demonstration Project :

GACID (Global Actinide Cycle International Demonstration), being initiated, by CEA, DOE and JAEA

- **Objective: to demonstrate, using Joyo and Monju, that FRs can transmute *MA*s in *homogeneous mode***
- **Material *properties* and *irradiation behavior* are also studied.**

Tri-lateral collaboration in GACID pin-scale tests.

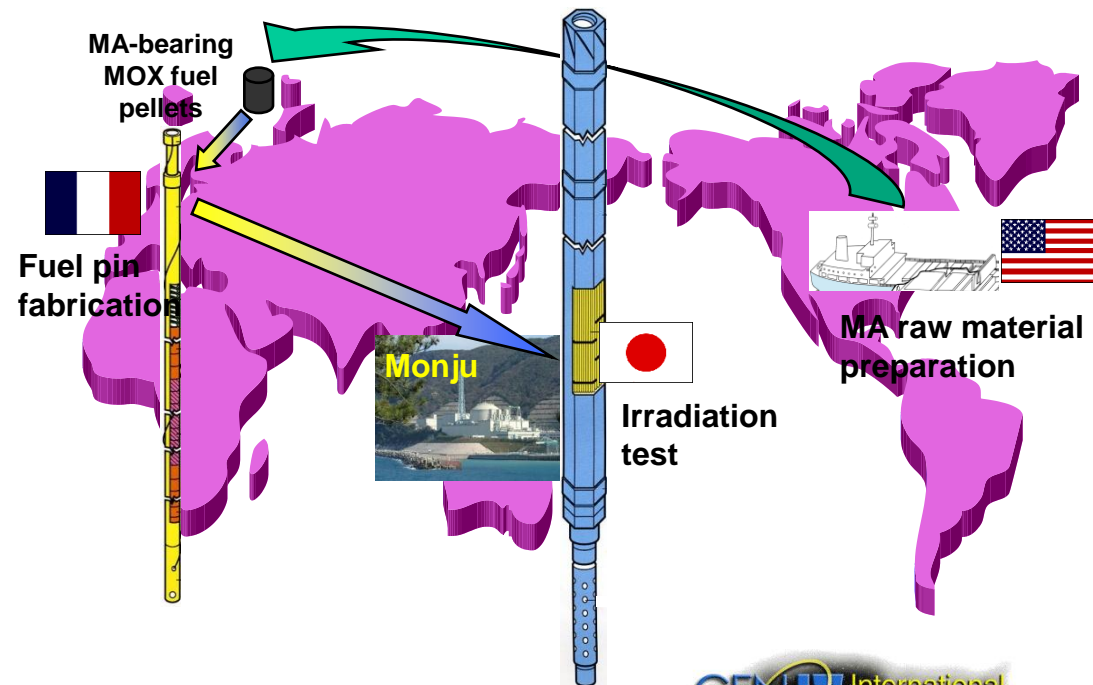

ADS demonstration:

In Europe, a series of demonstrations of separate **ADS** components, has been performed:

The physics of the sub critical core.....

A 1MW liquid LBE spallation target....

Some crucial components of a high intensity proton accelerator.....

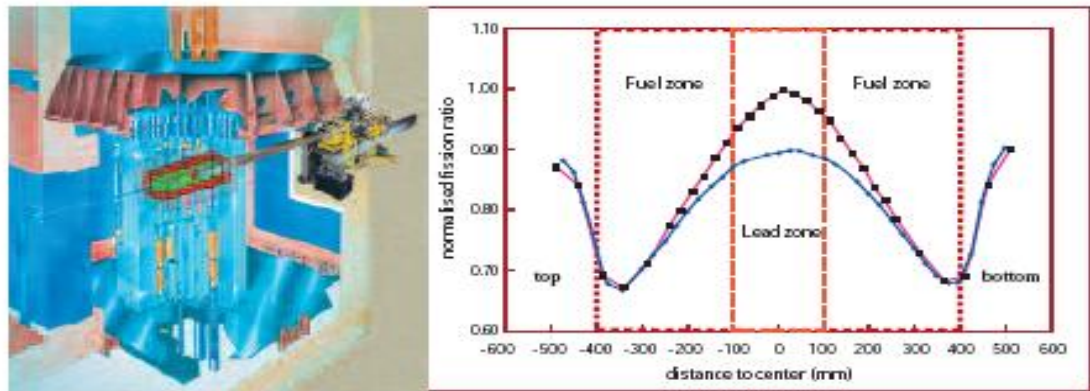

Figure D.8: Muse ADS experiment with the Masurca reactor and the Genevi accelerator; system power along a reactor section cross line (in blue: critical core without source, in red: subcritical mode with source).

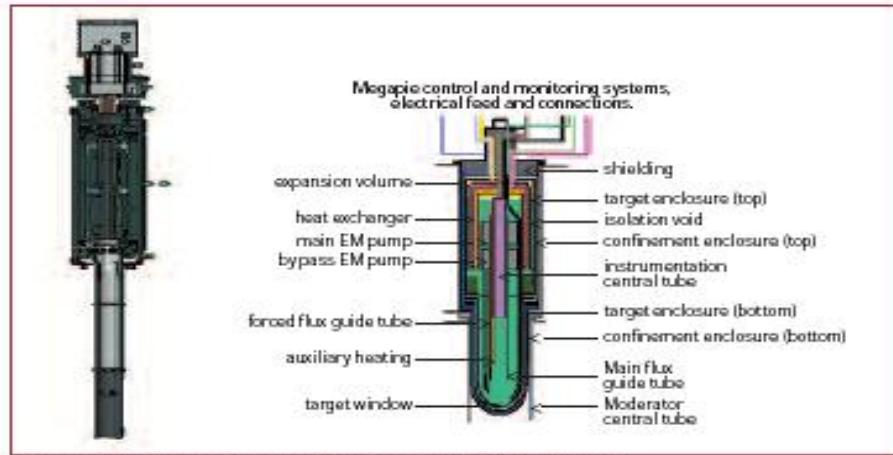

Figure D.9: Megapie spallation target (left: global view, right: detailed view).

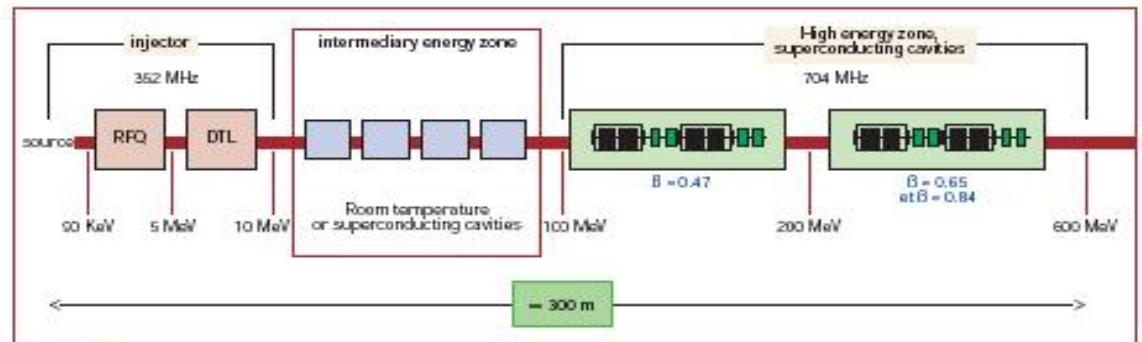

Figure D.10: scheme of an ADS linear accelerator.

...and a further challenge: if ADS would be needed, a full validation of the concept (i.e. coupling of components) is still to be made:

Pool type reactor and target module

Innovative Components:

- **Accelerator:**
~1 GeV protons, current
~10-20 mA
- **Subcritical core:**
MA-dominated fuel
- **Spallation target:**
solid or liquid metal:
W, Pb-Bi, Pb
- **Coolant:**
Pb-Bi, Pb, He, Na

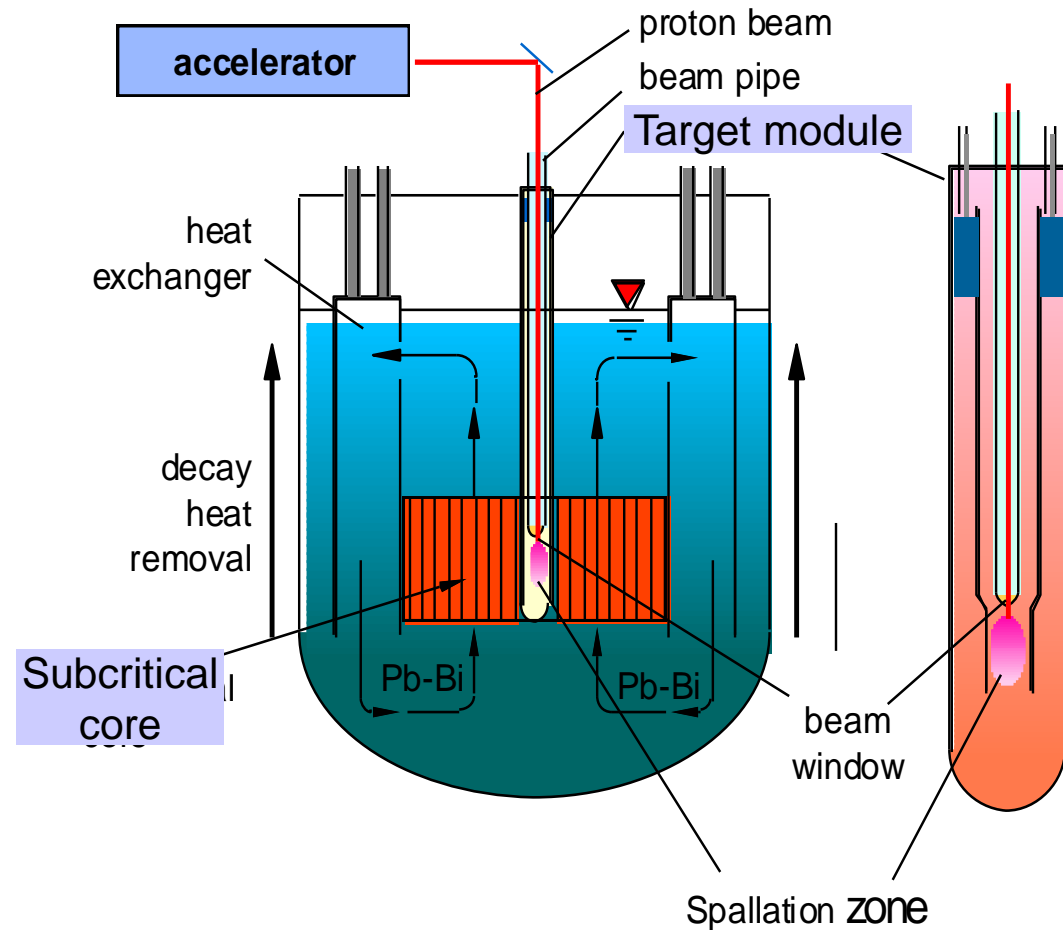

Cost Evaluations for Advanced Fuel Cycles

- Cost evaluations for advanced fuel cycles (including P/T) have been recently performed in the frame of two different OECD-NEA working groups.
- In particular, cost evaluations have been performed for the two major strategies for implementing P/T, i.e. the „double strata“, where ADS multi-recycle MA, and the full recycling of not-separated TRU in fast reactors.
- The increase in electricity cost due to advanced fuel cycles, has been found to be “relatively” limited (10% to 20%) compared to the once through fuel cycle
- However the authors of the studies underline the uncertainties associated to these evaluations.
- Moreover technical uncertainties on some innovative techniques, their feasibility and performance should be accounted for.

Cost Evaluations for Advanced Fuel Cycles

Reference: Advanced Fuel Cycles and Waste Management. OECD/NEA Publication.

RCOST (%)

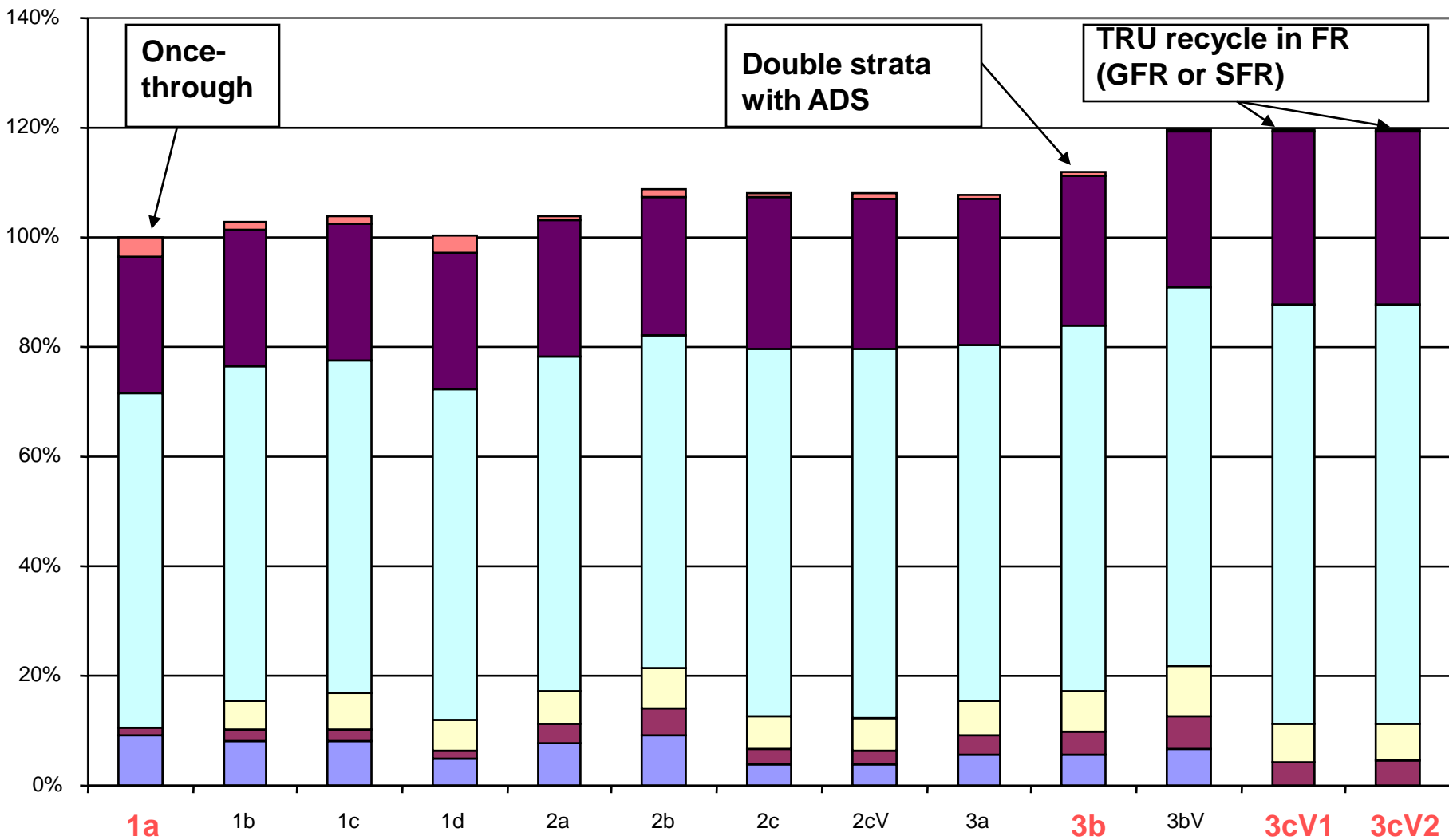

■ U, Conversion, Enrichment
 ■ Fuel Fabrication
 ■ Reprocessing
 ■ Reactor Investment
 ■ Reactor O&M
 ■ Waste Management

A Regional Approach to the Fuel Cycle with P/T

- Different countries can envisage different policies. According to the strategy, specific fuel cycle facilities have to be deployed.
- Some of these facilities are similar, even if conceived for different strategies.
- The multiplication of such facilities is unlikely, both for **non-proliferation** and **economic** reasons
- Can a **regional** (i.e. with some shared installations and combined resources) approach help ? (Consistent with provider/user state concept).
- **As an example, consider the case of:**
 - **A country group « A »**, which has a spent fuel legacy, no reprocessing installations and no decision yet on final repository.
 - **A country group « B »**, which has an operating power reactor fleet with a waste minimisation objective, has reprocessing capabilities, but looks for an optimisation of resources and investments.

Scenario 1:

This scenario considers the deployment of **fast reactors** in **Group B** countries. These fast reactors are deployed with the Plutonium of the two groups and recycle all the minor actinides.

The main objective of this scenario is to decrease the stock of spent fuel of countries A down to 0 at the end of the century and to introduce Gen-IV fast reactors in group B, starting, e.g., in 2035.

Scenario 2

This scenario considers the deployment of a number of **ADS** shared by the two groups of countries.

The ADS will use the Plutonium of the **Group A** and will transmute the minor actinides of the two groups.

The Plutonium of the **Group B** is continuously recycled in PWRs.

*The main objective of this scenario is to decrease the stock of spent fuel of countries of **Group A** down to ~0 at the end of the century, and to stabilize both Pu and MA inventories of **Group B**.*

The results of these preliminary studies show potential benefits for both groups of countries in terms of investments, use of resources etc.

However, there are major issues:

- Extensive transports of fuels**
- National independence**
- Repository siting (one “regional” site? How acceptable?)**
- Rationale for funding share**
-**

How to implement the “regional” concept in practice?

These studies are currently generalized to „global“ fuel cycle scenarios, in order to investigate U resources availability, type and time horizon of fuel cycle facilities needed etc

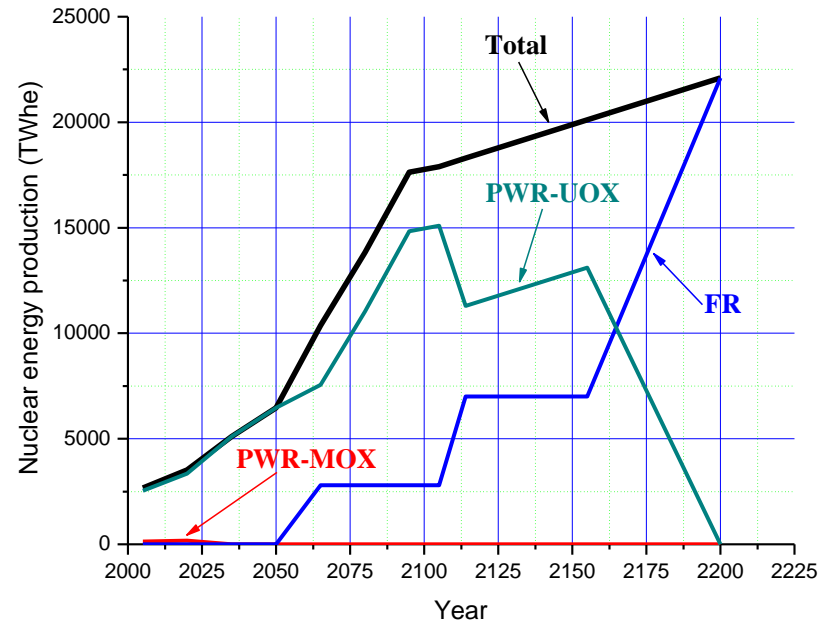
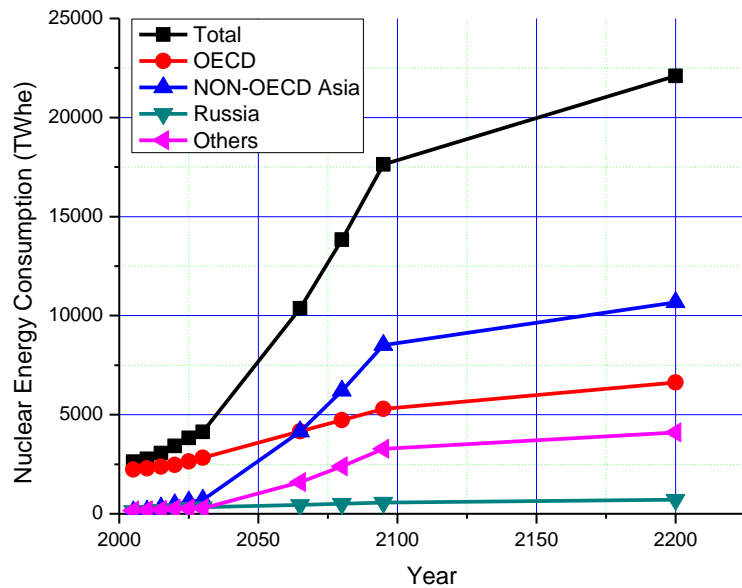

Conclusions

- P/T technologies offer the potential for a significant radioactive waste minimisation. However, there is still the need to agree on “meaningful” metrics to evaluate the potential impact.
- P/T can be applied to widely different fuel cycle strategies:
 - Sustainable development of nuclear energy**
 - Minimisation of the waste arising from a legacy of spent nuclear fuel**
- P/T **does not** eliminate the need for a deep geological storage whatever the strategy **but** allows to envisage the increase of its capacity, to reduce drastically the burden on it and improve public acceptance
- Fast Reactors offer the most flexible tool in order to implement P/T: The results of the studies clearly indicate a consensus on the fact that to reach the optimum performances of P/T, fast spectrum reactors and fully closed fuel cycles are needed, together with chemical processes which allow reaching ~99.9% recovery of all TRU.
- Demonstration of P/T implies the demonstration of all the “building blocks”: adapted fuels, adapted reprocessing techniques, reactor loaded with significant quantities of MA
- LLFP transmutation is questionable. However the Cs and Sr management is a relevant issue.